

THIS DRAWING IS UNPUBLISHED. RELEASED FOR PUBLICATION
 © COPYRIGHT - By - ALL RIGHTS RESERVED.

LOC	DIST	REVISIONS			
P	LTR	DESCRIPTION	DATE	DWN	APVD
AF	50	E1	REVISE PER ECR-14-006618	14MAY2014	GRZ JL

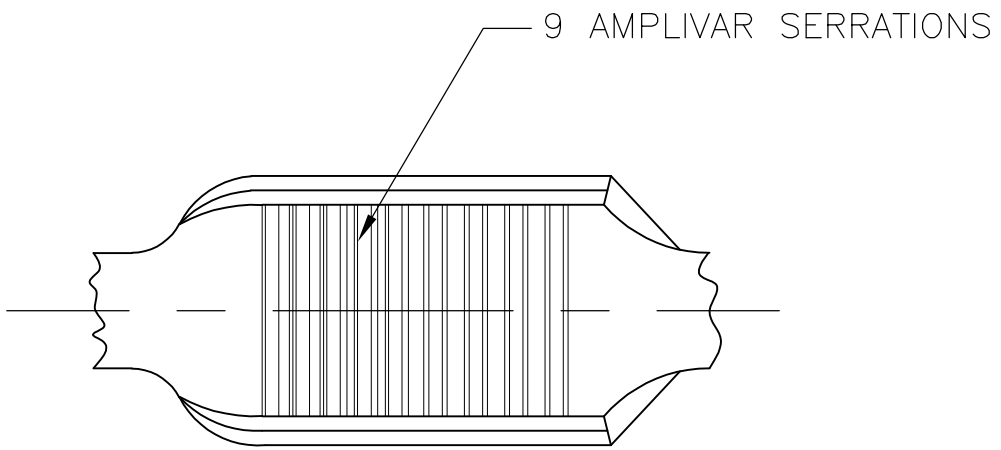

- PRODUCT PROVIDED IN STRIP FORM ON REELS; BREAKS MAY BE PRESENT.
- FOR FOREIGN USE ONLY
- DIMENSIONS IN BRACKETS ARE IN INCHES.
- CRIMP WIDTH: .110 F (AMPLIVAR TYPE)
 CRIMP HEIGHT (±.002)=(TOTAL CMA +7730)/188,900
 CRIMP WIDTH: .090 F (AMPLIVAR TYPE)
 CRIMP HEIGHT (±.002)=(TOTAL CMA +7300)/153,500
 GENERAL APPLICATION GUIDELINES MUST BE FOLLOWED AS SPECIFIED IN CATALOG # 82221
 FOR APPLICATOR INFORMATION CALL: 1-800-722-1111
 FOR PRODUCT INFORMATION CALL: 1-800-522-6752
- NOT FOR USE WITH ALUMINUM MAGNET WIRE. USE WITH COPPER MAGNET WIRE ONLY.

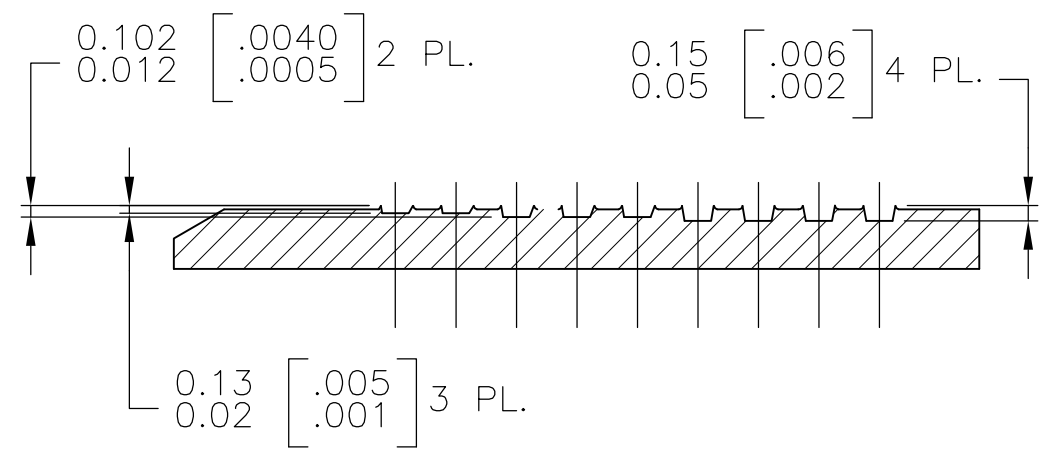
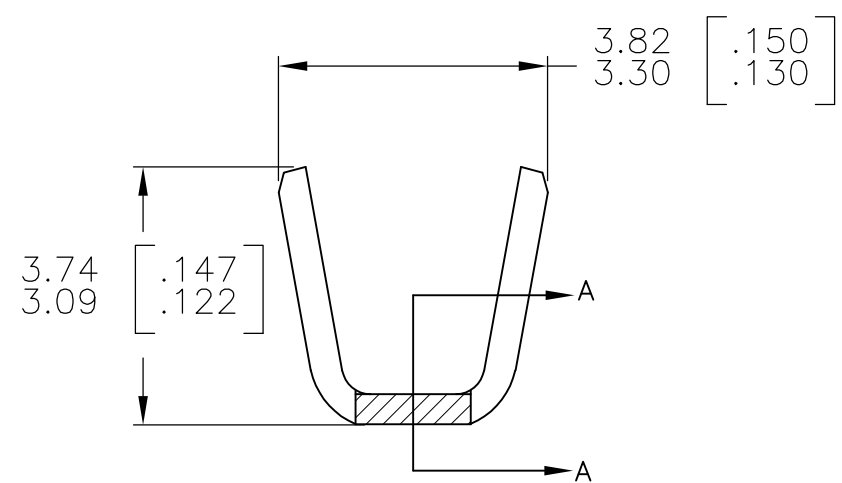
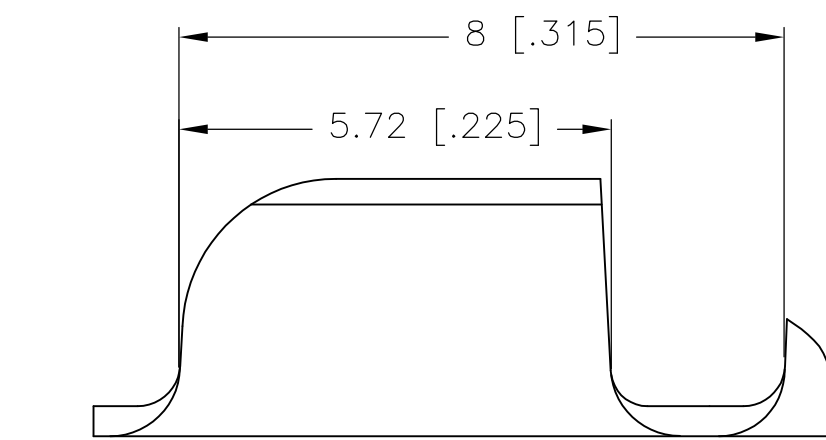

SECTION A-A
 SCALE : 20:1



(E)	0.41[.016] PHOS-BRONZE	TIN PL.	62305-3
	0.41[.016] BRASS	TIN PL.	62305-2
5	0.41[.016] BRASS	2	62305-1
	MATERIAL	FINISH	PART NO.

THIS DRAWING IS A CONTROLLED DOCUMENT.		DWN RAGHAVENDRA 30JAN06	STE TE Connectivity	
DIMENSIONS: mm [INCHES]		CHK G.D.PORTA		
TOLERANCES UNLESS OTHERWISE SPECIFIED:		APVD G.D.PORTA	NAME	
0 PLC ± -		PRODUCT SPEC	SPLICE, AMPLIVAR	
1 PLC ± -		APPLICATION SPEC	600-3000 CMA	
2 PLC ± 0.38[.015]		114-2003	SIZE	CAGE CODE
3 PLC ± -		WEIGHT -	A3	00779
4 PLC ± -		CUSTOMER DRAWING	DRAWING NO	RESTRICTED TO
ANGLES ± 1°		SCALE 10:1	G-62305	1 OF 1
MATERIAL SEE TABLE	FINISH SEE TABLE	SHEET	REV E1	